

## Jet Pump

### TCH 100



### Technische data

#### Pomp:

Materiaal: Kunststof  
 As afdichting:  
 - mechanical seal, Car/Cer/NBR  
 Waaiertype: gesloten  
 Aansluiting: 1" binnendraad  
 Max. vloeistof temperatuur: 70 °C  
 Max. omgevingstemperatuur: 50 °C  
 Gewicht: ± 12 kg  
 Incl. aan/uit schakelaar

#### Motor:

Spanning: 230 v, 50 Hz  
 Vermogen: 1,0 kW  
 Maximale stroom: 6,2 A  
 Toerental: 2900 rpm  
 Beschermingsklasse: IP55  
 Kabellengte: 1,5 m  
 Isolatieklasse: F  
 Condensator: 30 µF / 450V

Ingebouwde automatische thermische beveiliging (alleen monofase)  
 Geschikt voor continu gebruik

### Toepassing:



Industrie



Schoonwater



Hobby



Regenwater hergebruik

### Afmetingen

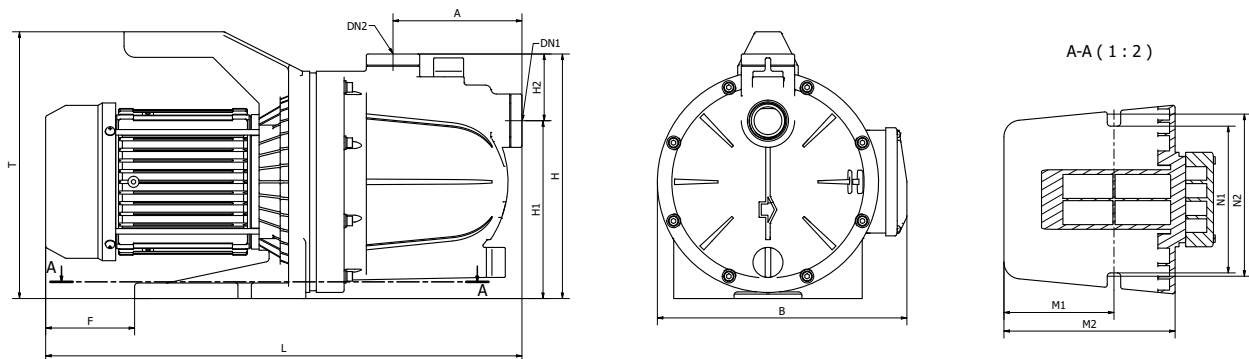

Letter	B	L	T	F	M1	M2	N1	N2	DN1	DN2	H1	H2	A
mm	224,5	429	240	80	99	154	132	146	1"	1"	160	60	114,5

### Curves

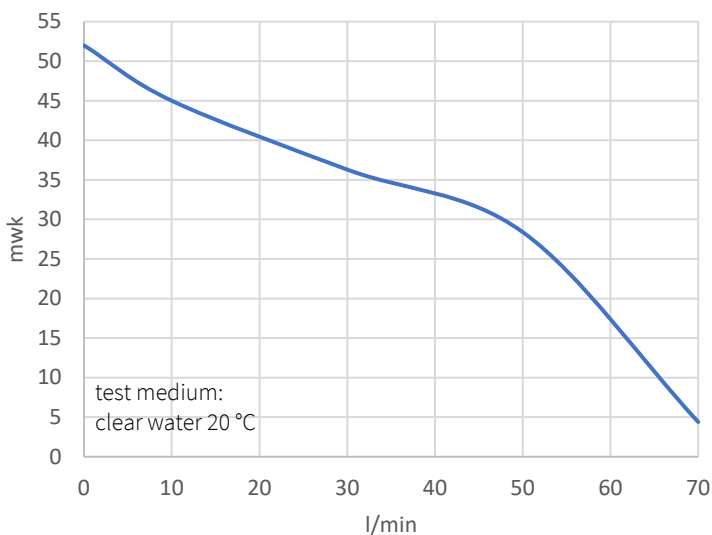

l/min	0	10	30	50	70
m <sup>3</sup> /h	0	0,6	1,8	3	4,2
<b>Pomptype</b>	<b>opvoerhoogte in mwk</b>				
TCH 100	52	45	36,3	28,4	4,4